



# TESTA\_e COMPACT

TEMPERATURE TEST CHAMBERS



  
aralab





**ARALAB** is a company specialised in designing, developing, manufacturing and servicing of high quality climatic chambers and controlled environment rooms.

Since 1985 we have been perfecting ways to create and control temperature, humidity, light, air flow and many other environmental conditions.

Only the highest quality components are used to manufacture our chambers so customers can have the best equipment for their research and testing purposes.

**Control the environment, Your own climate.**

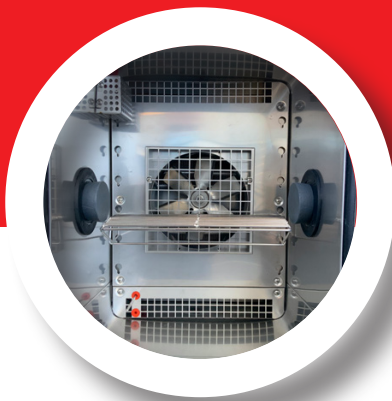

**Testa\_e temperature and humidity testing chambers offer precise and reproducible conditions for climatic and temperature testing in many industries.**

**COMMON APPLICATIONS INCLUDE:**

- ENVIRONMENTAL TESTING
- ELECTRONICS, AUTOMOTIVE, AEROSPACE,
- BUILDING MATERIALS, MILITARY EQUIPMENT, MATERIALS IN GENERAL RESEARCH
- QUALITY CONTROL
- PRODUCTION FACILITIES











**KEY FEATURES**

- The most advanced technology in climate control
- Internal aerodynamic optimisation to ensure uniformity of climatic conditions
- Time saving features with easily configurable testing programs that can run, start and stop automatically
- Highly resistant stainless steel interior for maximum durability and easy cleaning
- Flexible interior with height adjustable and removable stainless steel shelves
- Nonpolluting construction and cooling system
- Compliant with international standards and requirements EN, IEC, DIN, ISO, NP and UNE

## TEMPERATURE CONTROL RANGES

### ● ● ● ● COMPACT SERIES

#### TESTA\_e COMPACT 60 E80

TEMPERATURE RANGE		-80°C~+150°C
TEMPERATURE FLUCTUATION		≤0.5°C
TEMPERATURE DEVIATION		±2.0°C (>100°C); ±1.5°C (≤100°C)
TEMPERATURE UNIFORMITY		2.0°C (100°C); 1.5°C (≤100°C)
TEMPERATURE HEAT-UP RATE		+20°C→+150°C ≤25 min (setting valve at +155°C, measuring point at air inlet)
TEMPERATURE PULL-DOWN RATE		+20°C→-70°C≤55 min (setting valve at -75°C, measuring point at air inlet)
TEMPERATURE CHANGE RATE		Heat up: ≥ 6°C/min; Pull-down: ≥ 2°C/min PS: measuring point at air inlet, Refer to the standard IEC 60068-3-5
NOISE LEVEL		≤55dB(A) (1m in front of the gate, at 1.2 m above the ground, in a free space.)

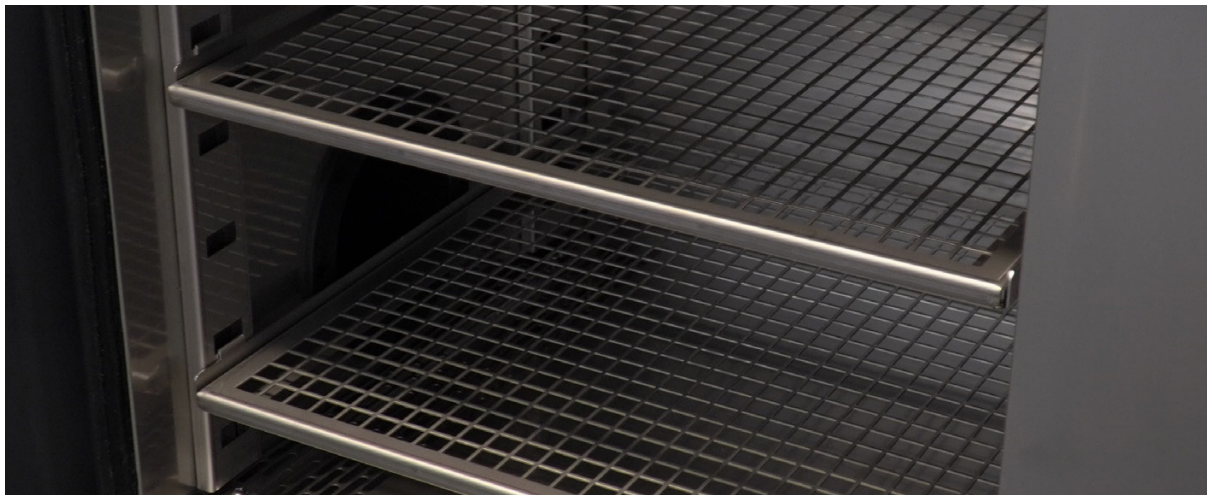

## DIMENSIONS AND DRAWINGS

### ● ● ● ● TESTA\_E COMPACT 60/80

EXTERNAL DIMENSIONS (HxWxD) (mm)		1 284 x 900 x 604
INTERNAL DIMENSIONS (HxWxD) (mm)		375 x 400 x 400

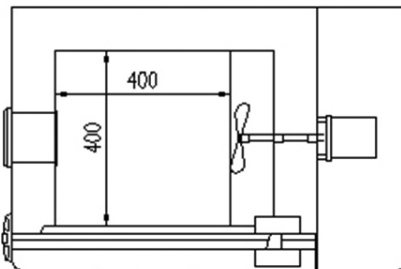
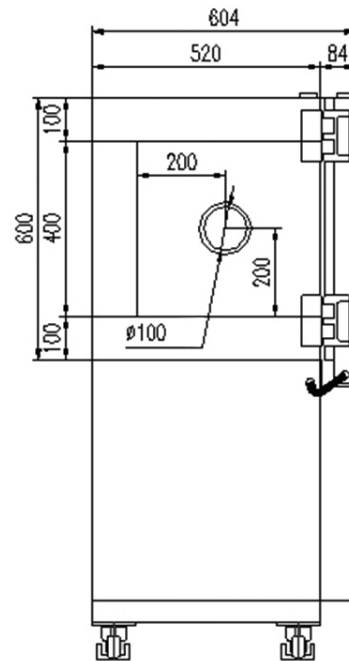
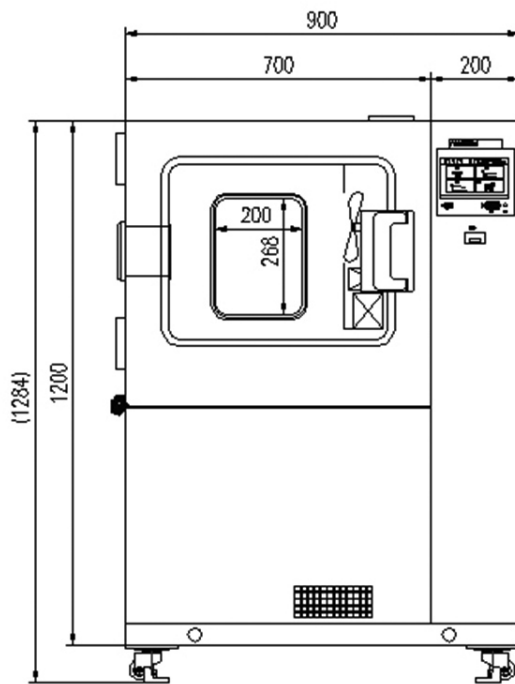

## INSTALLATION REQUIREMENTS

### POWER SUPPLY

- **Testa\_e Compact 60 E80 (3Phase):** AC(380±38)V (50±0.5)Hz 3-phases four wires + protective grounding wire. Suggested capacity for power switch 16A
- **Testa\_e Compact 60 E80 (1Phase):** AC(220±22)V (50±0.5)Hz Single phase + protective grounding wire. Suggested capacity for power switch 25A
- The earth resistance of protective grounding wire is less than 4Ω;
- Users are required to provide air or power switches with appropriate capacity for equipment at the installation site, and the switch must be independently provided for this equipment.

### POWER CAPACITY

- Testa\_e Compact 60 E80 (3Phase): 3.5kW
- Testa\_e Compact 60 E80 (1Phase): 3.5kW

### MAXIMUM CURRENT

- Testa\_e Compact 60 E80 (3Phase): 7A
- Testa\_e Compact 60 E80 (1Phase): 16A

## EQUIPMENT DESCRIPTION

### ● ● ● ● CONSTRUCTION

<b>INSULATION ENCLOSING STRUCTURE</b>	<ul style="list-style-type: none"> <li>Outer wall: two-sided galvanized steel sheet with plastic-sprayed surface (GWS standard color)</li> <li>Inner wall: SUS304 stainless steel plate</li> <li>Thermal insulating material for chamber body: polyurethane foam + glass wool</li> <li>Thermal insulating material for door: glass wool</li> </ul>
<b>AIR CONDITIONING CHANNEL</b>	<ul style="list-style-type: none"> <li>Fan, heater, evaporator, water drainage port, dry-bulb temperature transducer</li> </ul>
<b>TEST CHAMBER DOOR</b>	<ul style="list-style-type: none"> <li>Single hinged door with the hinge at the left side and knob on the right side</li> <li>viewing window, LED lamp</li> <li>Water sink</li> <li>Dew-prevention electric heating device on window frame</li> </ul>
<b>OBSERVATION WINDOW</b>	<ul style="list-style-type: none"> <li>One electric heating anti-sweat and dew-prevention viewing window</li> <li>W200mm×H265mm</li> </ul>
<b>CABLE PORT</b>	<ul style="list-style-type: none"> <li>ø100mm x1, at the left side of the chamber with soft rubber plug.</li> </ul>
<b>LAMP</b>	<ul style="list-style-type: none"> <li>High efficiency and long life LED light</li> </ul>
<b>CONTROL PANEL</b>	<ul style="list-style-type: none"> <li>Controller display, hour meter, over-temperature protection setting device, hour meter</li> </ul>
<b>MACHINERY ROOM</b>	<ul style="list-style-type: none"> <li>Refrigeration unit, water receiving pan, drainage port, blower fan for refrigeration, filter screen for condensers</li> </ul>
<b>DISTRIBUTION CONTROL CABINET</b>	<ul style="list-style-type: none"> <li>Motor, exhaust fan</li> <li>Distribution panel</li> <li>Leakage circuit breaker for general power supply</li> <li>Measuring device (ADDA)</li> <li>Input &amp; output (I/O) board</li> <li>RS-485 interface</li> <li>RJ-45 Ethernet interface</li> <li>Sample power supply control terminal</li> </ul>
<b>HEATER</b>	<ul style="list-style-type: none"> <li>Nichrome strip wire heater</li> <li>Control method of heater: equivalent periodic pulse-width modulation without contact, SSR (solid-state relay)</li> </ul>
<b>POWER CORD HOLE AND DRAINAGE HOLE</b>	<ul style="list-style-type: none"> <li>At the back side of chamber body</li> </ul>
<b>STANDARD CONFIGURATION OF TEST CHAMBER</b>	
<b>TEST SAMPLE SHELF</b>	<ul style="list-style-type: none"> <li>2 stainless steel shelves</li> <li>Load capacity (uniformly distributed):5 kg/layer</li> </ul>
<b>MOVABLE CASTERS</b>	<ul style="list-style-type: none"> <li>4 (with adjusting wheels)</li> </ul>

● ● ● ● **REFRIGERATION SYSTEM**

<b>HEAT TRANSFER</b>	<ul style="list-style-type: none"> <li>Heat transfer convection by air circulating</li> </ul>
<b>AIR CIRCULATION DEVICE</b>	<ul style="list-style-type: none"> <li>Centrifugal fan</li> </ul>
<b>AIR HEATING</b>	<ul style="list-style-type: none"> <li>Nichrome strip wire heater</li> <li>Control method of heater: equivalent periodic pulse-width modulation without contact, SSR (solid-state relay)</li> </ul>
<b>AIR COOLING</b>	<ul style="list-style-type: none"> <li>Testa_e Compact 60 E80: Mechanical compression cascade refrigeration(Air cooled)</li> </ul>
<b>REFRIGERATION COMPRESSOR</b>	<ul style="list-style-type: none"> <li>Capillary &amp; Electronic expansion valve (stepping motor driver)</li> </ul>
<b>REFRIGERATING MACHINE CONTROL METHOD</b>	<ul style="list-style-type: none"> <li>Hermetically sealed low-noise rotary compressor</li> </ul>
<b>REFRIGERANT</b>	<ul style="list-style-type: none"> <li>Testa_e Compact 60 E80: R449a/R508a</li> </ul>

## CONTROLLER

<b>DISPLAY</b>	<ul style="list-style-type: none"> <li>7 inches, 800X480 dot matrix, TFT 64k color LCD display</li> </ul>
<b>OPERATING MODE</b>	<ul style="list-style-type: none"> <li>Program mode: fixed value mode</li> </ul>
<b>SETTING MODE</b>	<ul style="list-style-type: none"> <li>English menu; input via touch screen</li> </ul>
<b>PROGRAM CAPACITY</b>	<ul style="list-style-type: none"> <li>Editable programs</li> <li>Quantity: 20 max</li> <li>Steps: 1 000 max</li> <li>Cycles: each step has a maximum of 20 cycles (each cycle step has a maximum of 99 cycles);</li> <li>Fixed: 10 programs that can be linked</li> </ul>
<b>SET RANGE</b>	<ul style="list-style-type: none"> <li>Temperature: adjust according to the temperature range of the equipment (Upper limit: +5°C; Lower limit: -5°C)</li> </ul>
<b>SET &amp; DISPLAY RESOLUTION</b>	<ul style="list-style-type: none"> <li>Temperature: 0.1°C</li> <li>Time: 0.1 min</li> <li>Humidity: (0~100) %RH</li> </ul>
<b>INPUT</b>	<ul style="list-style-type: none"> <li>Thermocouple</li> <li>Platinum resistance, voltage, current, etc., if the equipment needs</li> </ul>
<b>COMMUNICATION INTERFACE</b>	<ul style="list-style-type: none"> <li>RS-485 interface</li> <li>RJ-45 Ethernet interface (IEEE802.3i/3u/3ab, 100Mbps)</li> </ul>
<b>INTERFACE CONVERTOR (OPTION)</b>	<ul style="list-style-type: none"> <li>RS-232 interface: RS-485/ RS-232 convertor</li> <li>GPIB interface (IEEE 488.2): RS-485/GPIB convertor</li> </ul>
<b>COMMUNICATION PROTOCOL</b>	<ul style="list-style-type: none"> <li>STEN Communication protocol</li> </ul>
<b>CONTROL MODE</b>	<ul style="list-style-type: none"> <li>Anti-integral saturation PID</li> <li>BTC (for temperature test equipment)</li> </ul>
<b>CURVE RECORDING FUNCTION</b>	<ul style="list-style-type: none"> <li>RAM with battery protection can save the set values, sampling values of equipment, and the time of sampling instant. The maximum recorded time is 350 days (when sampling period is 1.5min).</li> </ul>
<b>AFFILIATED FUNCTION</b>	<ul style="list-style-type: none"> <li>Malfunction alarm, cause and treatment indicating function; power failure protection function; highest and lowest temperature protection function;</li> <li>Calendar timing function (automatic startup and shutdown)</li> <li>Self-diagnosis function</li> </ul>



## FITOLOG SOFTWARE

The FitoLog software pack is a set of applications designed to facilitate the monitoring and programming and data from the FitoClima chambers. It consists of 3 applications: **FitoLog**, **FitoLogView** and **FitoProgram**.

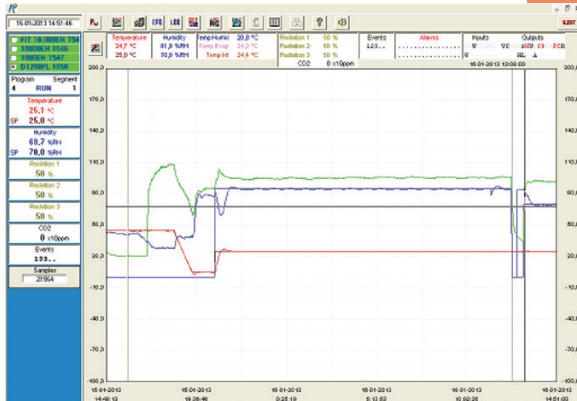

### FITOLOG

Records and displays in real time all data and details related to the set-points, running variables and equipment behaviour.

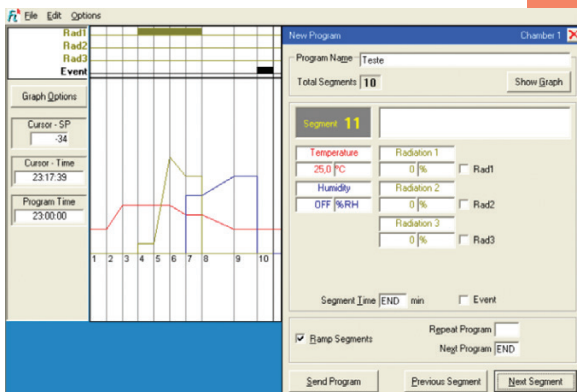

### FITOPROGRAM

This application simplifies the creation of programs and its integration on the chamber ClimaPlus controller. Up to 20 programs, each with 50 segments, can be designed and linked to create detailed environmental profiles and simulations.

## ACCESSORIES

- Additional shelves
- Observation window

Let's meet!

[aralab@aralab.pt](mailto:aralab@aralab.pt)

[www.aralab.pt](http://www.aralab.pt)

T: +351 219 154 960



Configure your  
chamber 

See it on the  
Showroom 

 /AralabChambers

 /company/aralab

 /user/AralabChambers

 /Aralab\_

 /aralabchambers



**Control the environment**

Your own climate